

1.0 GALLON

SOFT SERVE



QK1 GELATO MACHINE

QK1
Gelato Machine



Shown in white. Also available in black.

1.0 Gallon QK1 Gelato Machine is the latest innovation from Elmecco, created for preparation of creamy and delicious premium soft serve gelato, frozen yogurt, shakes and smoothies. Within approximately 1.5 hour, QK1 prepares up to 200 oz. of finished soft serve product. Equipped with programmable Automatic Defrost Timer, which turns the machine on and off at pre-set time.

BENEFITS & FEATURES



User-Friendly Electronic Touch Pad:

With patented dispensing system, QK1 provides portion controlled servings of approximately 2.5 oz. each.

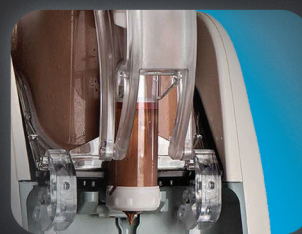

Patented nozzle:

Guarantees fast and clean dispensing.



Patented Total Cold Refrigeration System:

Keeps product at a constant temperature to the very last portion.

Innovative, Removable External Condenser:

Air filter makes the periodical maintenance a snap.

Color Choices:



Water Specification

Water Inlet 3/8" Male Flare Fitting	Minimum Flow Rate 1 1/2 gpm [5.8 lpm]	Water Pressure 20-75 psig [138-517 kPa]
--	--	--

Temperature

Max <> Min 16.7 <> 25.7°F [-8.5 <> -3.5°C]

Electrical Configuration

Model	Configuration Code	Description	Amps	Voltage	Phase	Wires	Watts	Compressor	Electrical Connection
QK1	US / CANADA PEL0601	Single Bowl Gelato	7.4	115 (60Hz)	1	2+G	850	1/3 HP	NEMA 5-15P 

Measurements

Model	Width	Depth	Height	Capacity	Empty Weight	Filled Weight
QK1	11.0" [27.6 cm]	19.0" [47.1 cm]	28.0" [71.2 cm]	1.0 G [4.0 l]	65 lbs [30.0 kg]	73.3 lbs [33.3 kg]

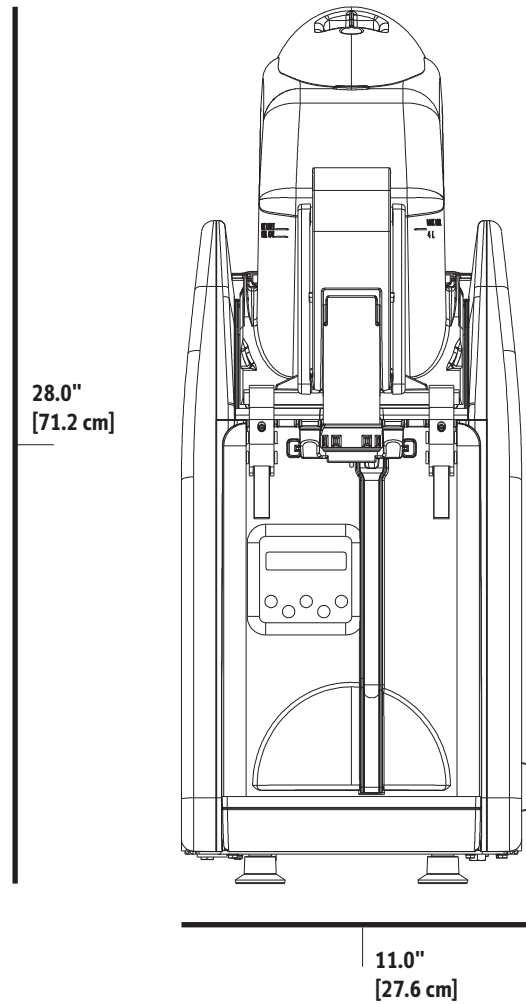
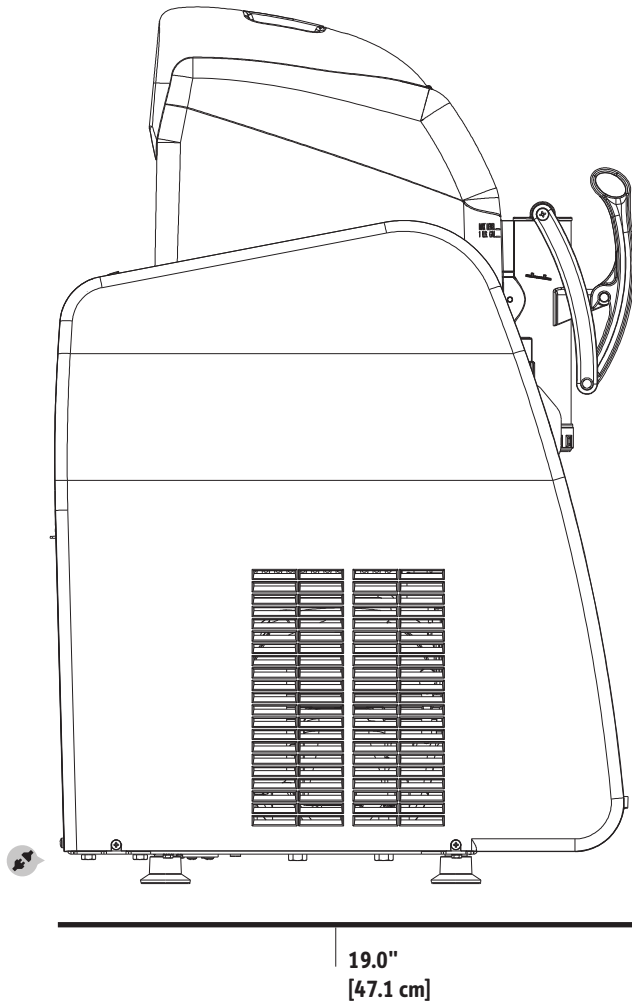

Information

 fetco.com
 orders@fetco.com

 847.719.3000
 1.800.338.2699 USA
 847.719.3001

 Food Equipment Technologies Co.
 600 Rose Road
 Lake Zurich, IL 60047
 USA